

Bottom view
Scale: 3:4

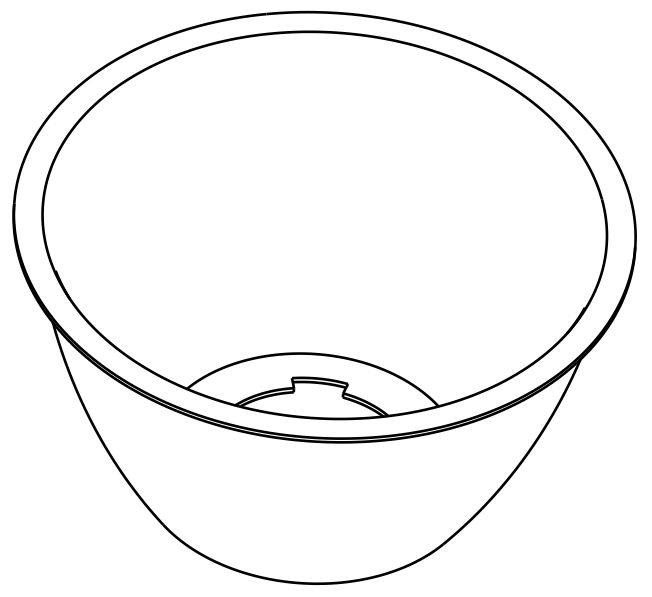

Isometric view
Scale: 3:4

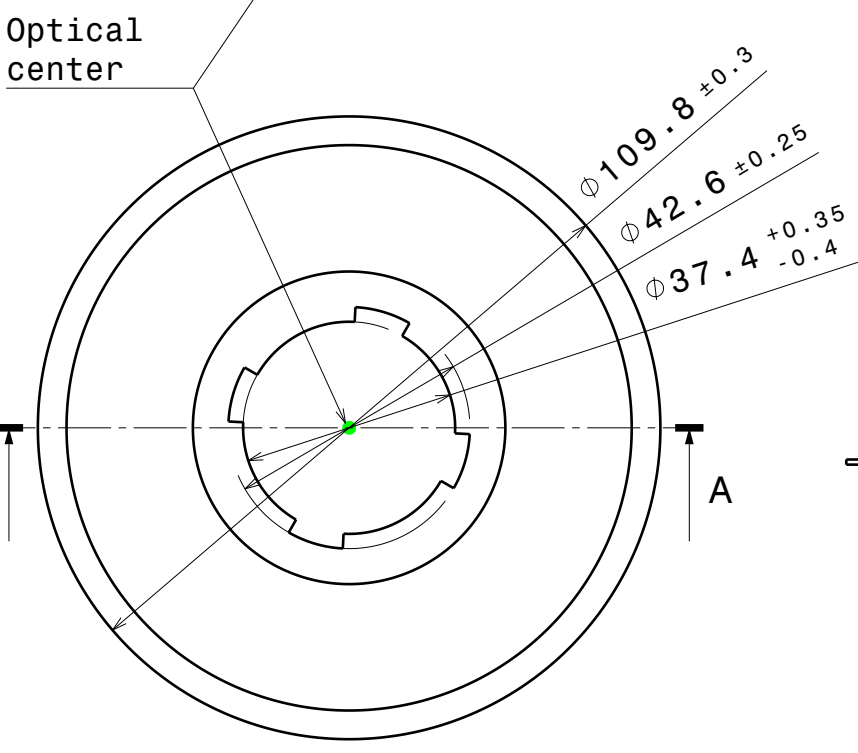

Front view
Scale: 3:4

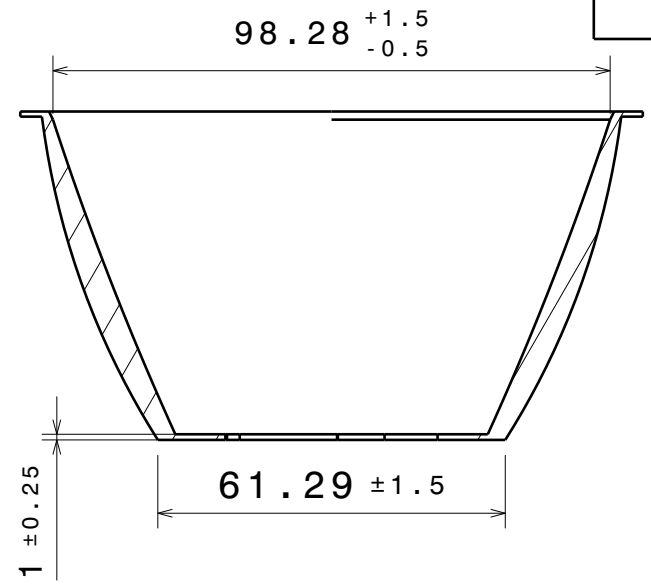

Section view A-A
Scale: 3:4

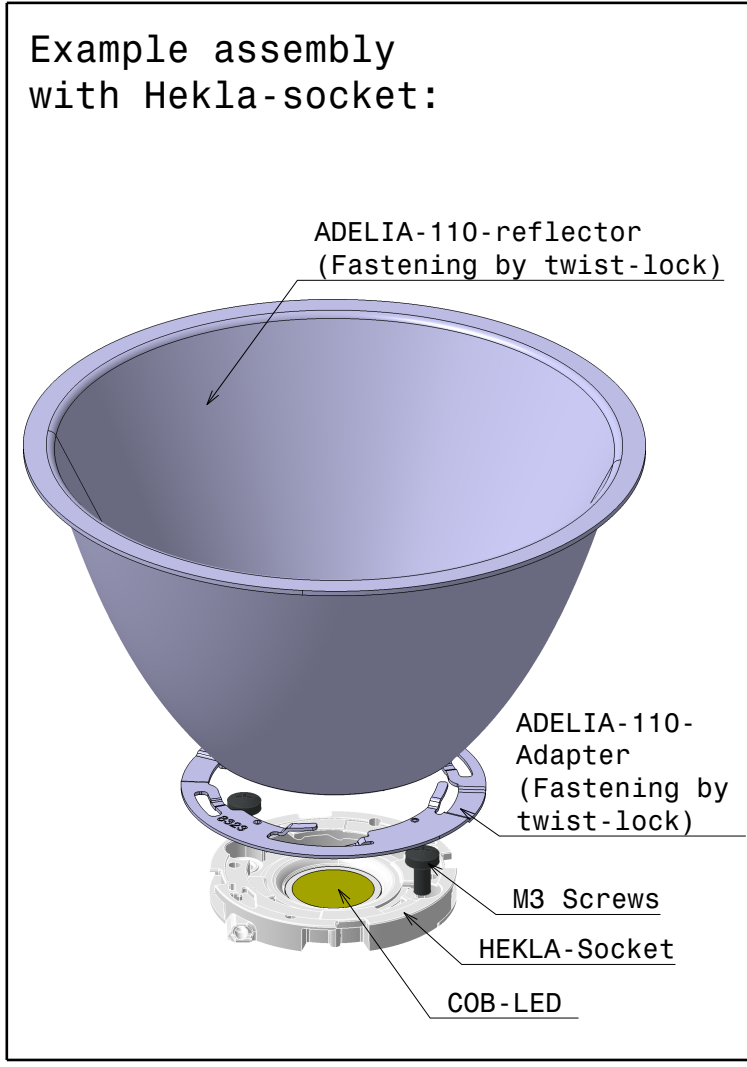

Example assembly
with Hekla-socket:

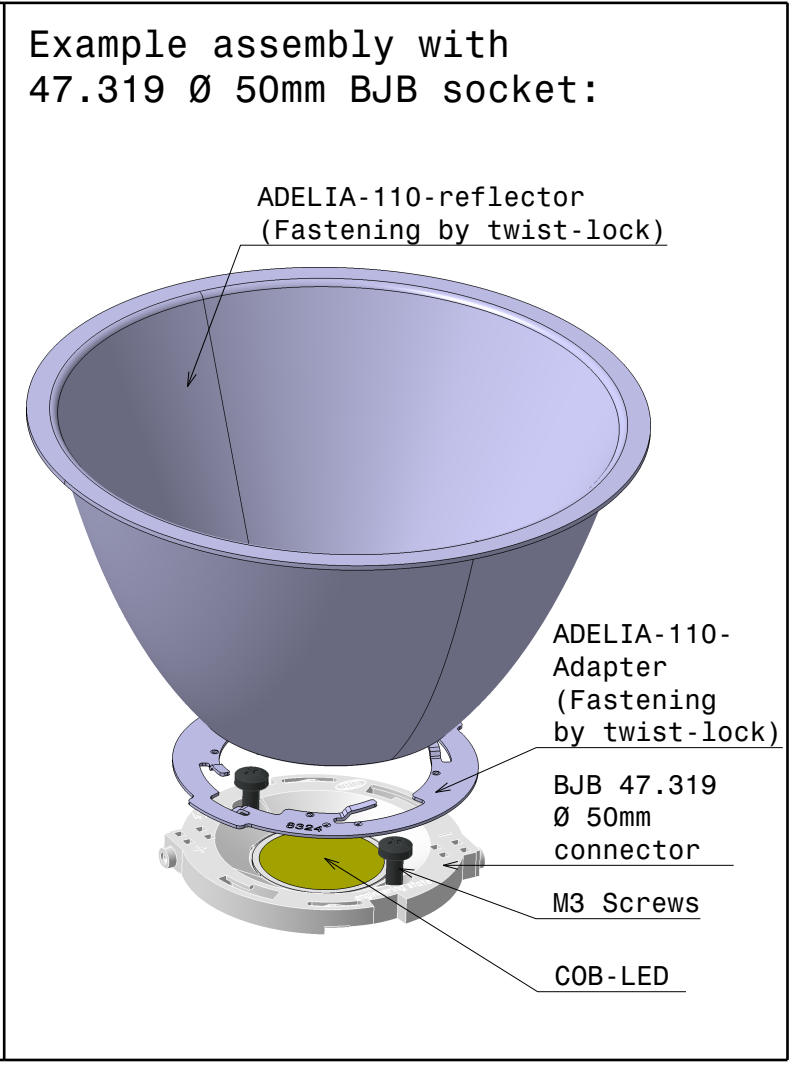

Example assembly with
47.319 Ø 50mm BJB socket:

PART	TYPE	MATERIAL	COLOR / COATING
C18658_ADELIA-110-WW	Reflector	Aluminium	Polished

MECHANICAL DRAWING	
PRODUCT	ADELIA
Plastic moulding general tolerances according to DIN 16901-130 and applies if not otherwise shown in the drawing. Silicone moulding general tolerances according to ISO 3302-1 Class M3 and applies if not otherwise shown in the drawing.	FIRST ANGLE PROJECTION:
SCALE	3:4
WEIGHT	-

LEDiL

This drawing is the property of LEDiL Oy. It may not be copied or otherwise distributed without prior written permission from LEDiL Oy.

A3 SHEET 1/1

Notes

	PCB or heatsink level.
	LED location
	Ensure LED fitting from a product specific 3D model available from www.ledil.com
	For more details about installation please see LEDiL Installation Guide on www.ledil.com